

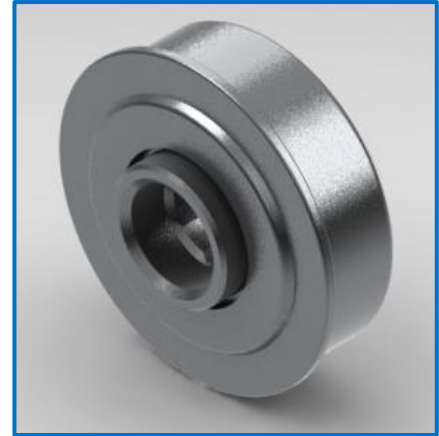

# 1634

## Unground / Commercial Bearing



### Specifications

- Bearing Type:** Flanged Unground Commercial
- Load Capacity:** 125 lbs.
- Mounting Type:** Press Fit
- Tube Size/Gauge:** 1.9" x 9g
- Max OD of Body:** 1.628"
- Bore Size & Type:** 7/16" – Hex
- Extension:** 0.250"
- Lubrication:** Oil or Grease
- Temperature Range:** Oil, -10 to 400 F°  
Grease, -40 to 300 F°
- Protection:** Front – Seal Plate  
Rear – Shield Plate
- Regreasable:** No – Maintenance Free

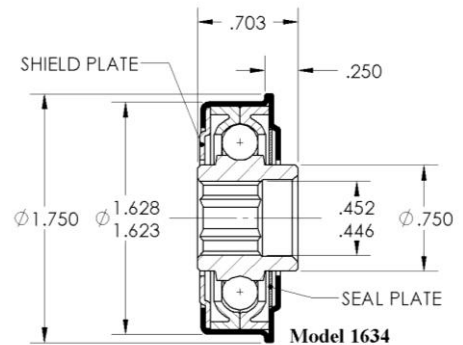

Part Number for Ordering: Oil – 1634226023  
Grs – 1634226123

### Applications: Benefits & Features

- Non-Precision Bearings:** FRANTZ Non-Precision bearings offer the least rolling resistance, lower energy consumption and overall a greener option. Engineered to accommodate more axle deflection due to heavy loads or shock, especially when used in longer rollers (as compared to Precision or Semi-Precision bearings), often making non-precision bearings the product of choice in many conveyor designs.
- Targeted Applications:** This bearing often used gravity conveyors for distribution/warehousing, food & beverage, air cargo/airports, manufacturing equipment and packaging equipment. The bearings are ideal in gravity applications at low to medium speeds, while the oil version offers the least rolling resistance. The grease option can be used in powered conveyor applications.
- Long Life:** FRANTZ non-precision bearings are engineered and tested to exceed the CEMA standard of one million revolutions.

FRANTZ

...Roll Easy with FRANTZ®

Customer Service, Product Samples and Quotations: 815.625.7063

FRANTZ Manufacturing Company P.O. Box 497, Sterling IL 61081-0497 [www.frantz-mfg.com](http://www.frantz-mfg.com)