



418

Radial Thrust, Non-Precision Bearing

Specifications

Bearing Type:	Flanged Unground Commercial
Load Capacity:	300 lbs.
Mounting Type:	Press Fit *
Tube Size/Gauge:	1.9" x 12g
Max OD of Body:	1.712"
Bore Size & Type:	7/16" – Hex
Extension:	9/64"
Lubrication:	Oil or Grease
Temperature Range:	Oil, -10 to 400 F° Grease, -40 to 300 F°
Regreasable:	No – Maintenance Free

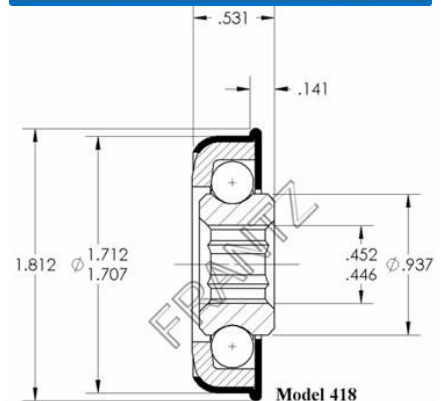
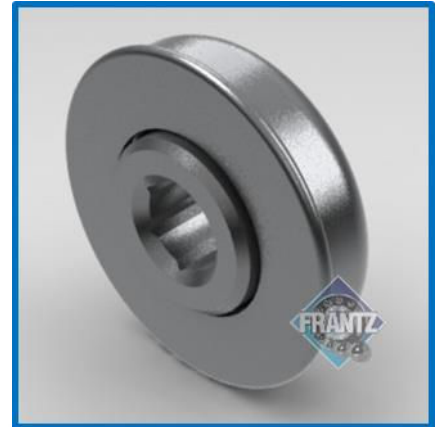

Part Number for Ordering: Oil – 0418226023
Grs – 0418226123

Applications: Benefits & Features

Radial Thrust Non-Precision Bearings: In certain applications, conveyor bearings are subjected to lateral forces particularly in turns, merges, and loading areas. For these situations, FRANTZ has designed conveyor bearings with a single heat treated outer race and ball complement enclosed by a shell. This design provides a durable "corner" to withstand the lateral forces permitting longer conveyor bearing life. Radial Thrust Conveyor Bearings perform perfectly well in situations where force is linear too, but give you the corner when it is needed. FRANTZ Non-Precision bearings offer the least rolling resistance, lower energy consumption and overall a greener option. Engineered to accommodate more axle deflection due to heavy loads or shock, especially when used in longer rollers (as compared to Precision or Semi-Precision bearings), often making non-precision bearings the product of choice in many conveyor designs.

Targeted Applications: Gravity conveyors for distribution/warehousing, food & beverage, air cargo/airports, manufacturing equipment and packaging equipment. The 418 bearing along with other 400 series bearings, are often used as a replacement for Litton bearings. Litton Unit Handling Systems no longer manufactures bearings, however their products had an extensive installed base, occasionally still seen in operation today.

Long Life: FRANTZ non-precision bearings are engineered and tested to exceed the CEMA standard of one million revolutions.

* In Press Fit application, FRANTZ recommends a tube inside diameter with no less than 0.003" to 0.008" press fit interference. Contact FRANTZ Customer Service if you have questions regarding Press Fit applications.

...Roll Easy with FRANTZ®

FRANTZ

Customer Service, Product Samples and Quotations: 815.625.7063

FRANTZ Manufacturing Company P.O. Box 497, Sterling IL 61081-0497 www.frantz-mfg.com