

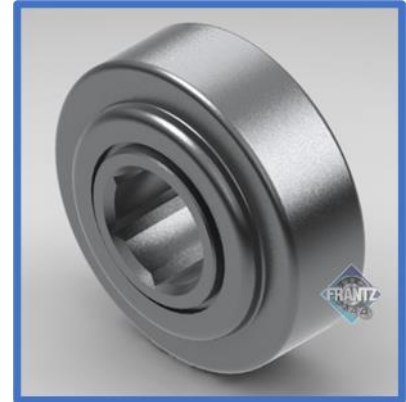

3185

Semi-Precision Bearing



Specifications

- Bearing Type:** Straight Faced Semi-Precision
- Load Capacity:** 1,250 lbs.
- Mounting Type:** Counterbore & Press Fit
- Tube Size/Gauge:** 3.5" x 0.30" *
- Max OD of Body:** 3.066"
- Bore Size & Type:** 1-1/16" – Hex
- Extension:** 0.250"
- Lubrication:** Oil or Grease
- Temperature Range:** Oil, -10 to 220 F°
Grease, -4 to 220 F°
- Protection:** Front – Labyrinth Shield
Rear – Shield Plate
- Regreasable:** Yes. Domed Back Plate

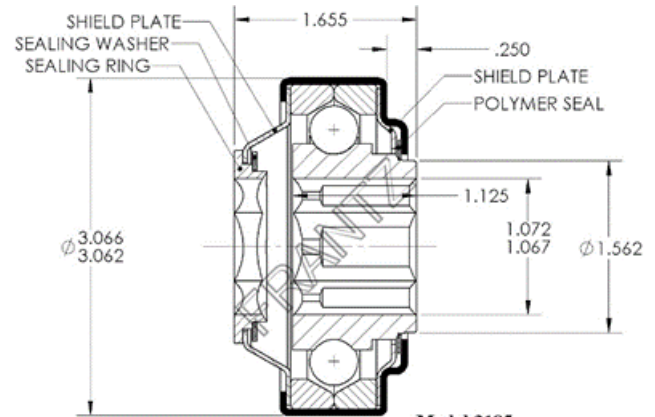

Model 3185

* Also press fit into 3-1/4" x 13g, 3-1/4" x 12g, 3-1/2" x 7/32", 3-5/8" x 9/32" and 3-3/4" x 11/32" tubes.

Part Number for Ordering:

Oil - 3185226023
Grs - 3185226123

Applications: Benefits & Features

Semi-Precision Bearing: FRANTZ 3100 Series is specially designed to be press fit into counterbored heavy wall tube. Rollers exposed to 'high-impact' shock zones and loads are suitable for the 3100 Semi-Precision Series. Precise machined outer races and the use of high precision chrome balls are distinguishing factors that allow for heavier load capacities. Seals and/or shield options help prevent contamination from entering the rolling elements.

Targeted Applications: Gravity, push or CDLR powered conveyor applications at low to medium speeds used primarily in packaging, palletizing, shipping/warehousing, foundries, cargo dollies and assembly where high load capacity is required or where heavy 'impact zone' bearings are required.

Ball Quality: FRANTZ utilizes high precision chrome balls in the 3100 Series to support heavier load capabilities, thus providing another level of quality over competitive models.

Long Life: FRANTZ 3100 Series Semi-Precision bearings are engineered and tested to exceed the CEMA standard or one million revolutions.

...Roll Easy with FRANTZ®

FRANTZ

Customer Service, Product Samples and Quotations: 815.625.7063

FRANTZ Manufacturing Company P.O. Box 497, Sterling IL 61081-0497 www.frantz-mfg.com