

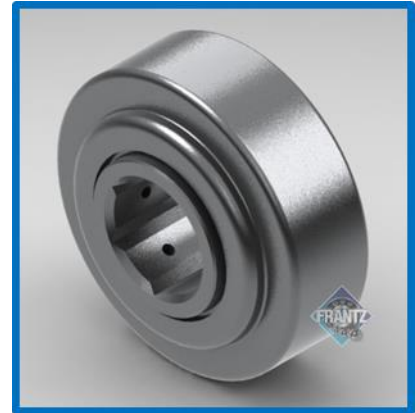

3080

Unground / Commercial Bearing



Specifications

- Bearing Type:** Straight Faced Unground Non-Precision
- Load Capacity:** 603 lbs.
- Mounting Type:** Counterbore & Press Fit
- Tube Size/Gauge:** 3-1/2" x 0.30" *
- Max OD of Body:** 3.066"
- Bore Size & Type:** 1-1/16" – Hex
- Extension:** 0.250"
- Lubrication:** Oil or Grease
- Temperature Range:** Oil, -10 to 220 F°
Grease, -4 to 220 F° **
- Protection:** Front – Polymer Seal, Shield Plate
Rear – Shield Plate
- Regreasable:** Yes

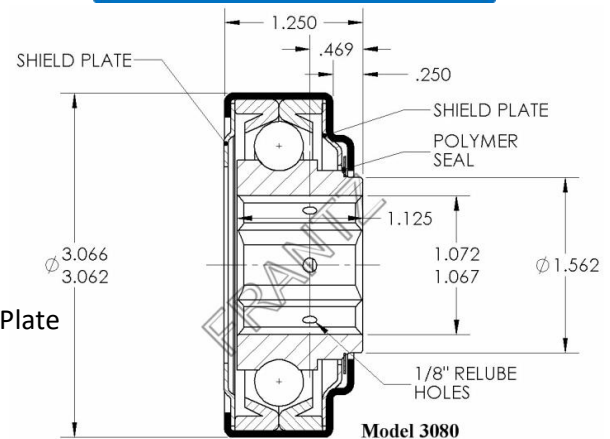

* Also press fit into 3-1/4" x 13g, 3-1/4" x 12g, 3-1/2" x 7/32", 3-5/8" x 9/32" and 3-3/4" x 11/32" tubes.

** Consult with FRANTZ Customer Service for high temp application recommendations.

Part Number for Ordering:
Oil - 3800226023
Grs - 3800226123

Applications: Benefits & Features

- Non-Precision Bearing:** FRANTZ Unground / Commercial bearings offer the least rolling resistance, lower energy consumption and overall a greener option. Engineered to accommodate more axle deflection due to heavy loads or shock, especially when used in longer rollers (as compared to Precision or Semi-Precision bearings), often making commercial bearings the product of choice in many conveyor designs. Dual outer race and full ball complement provides more contact between components allowing for more resistance to shock loading.
- Targeted Applications:** Gravity or powered conveyor applications at low to medium speeds used primarily in packaging, palletizing, shipping/warehousing, cargo dollies and assembly.
- Ball Quality:** FRANTZ also manufactures the balls used in the 3080 under strict IATF 16949:2016 quality standards designed for supporting the requirements of the auto industry, thus providing another level of quality over competitive models.
- Long Life:** FRANTZ Unground / Commercial bearings are engineered and tested to exceed the CEMA standard or one million revolutions.

...Roll Easy with FRANTZ®

FRANTZ

Customer Service, Product Samples and Quotations: 815.625.7063

FRANTZ Manufacturing Company P.O. Box 497, Sterling IL 61081-0497 www.frantz-mfg.com