

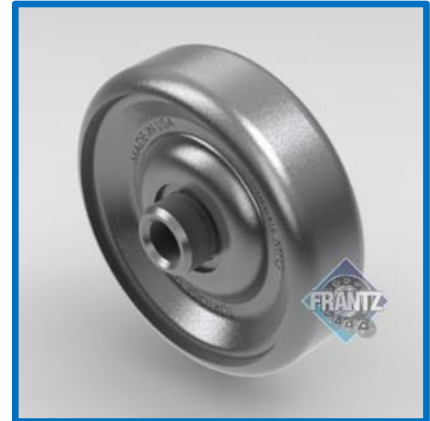

29

Conveyor / Skate Wheel



Specifications

- Wheel Type:** Non-Precision, Tortoise Shell®
- Load Capacity:** 200 lbs.
- Impact Rating:** 400 lbs.
- Body Diameter:** 1-15/16"
- Bore Size & Type:** 1/4" – Round; Length 7/8"
- Lubrication:** Oil or Grease
- Ball Complement:** (8) - 1/4" Diameter
- Material:** Zinc Plated Steel, Hardened Sterling® Steel Balls & Raceways
- Temperature Range:** Oil, -10 to 210 F°
Grease, -20 to 220 F° **
- Protection:** Labyrinth Shields, Polymer Seals
- Regreasable:** No – Maintenance Free
- Other:** No lube, & extreme cold oil available; contact Customer Service

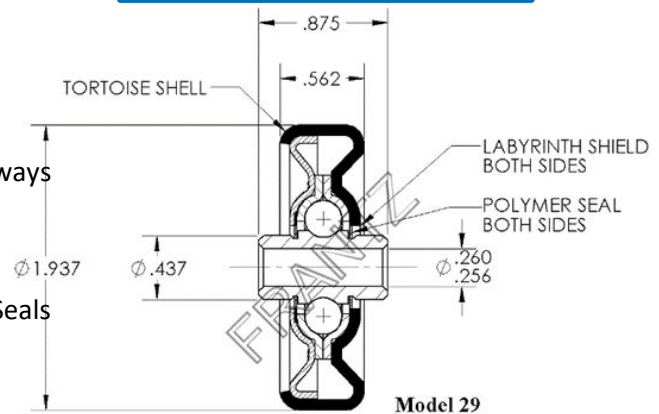

Part Number for Ordering:
 Oil - 0029216023
 Grs - 0029216123

** If grease is required with application temperatures above 220 F° please consult with FRANTZ customer service to discuss application and options.

Applications: Benefits & Features

- Impact Rating:** FRANTZ not only tests steel conveyor wheels for cycle revolutions under load, but also performs impact testing under ANSI spec ICWM:2012 which was developed for the caster industry. Impact rating provides user confidence in applications with heavy weight or load "impact zones".
- Targeted Applications:** Conveyor / skate wheels for straight or curved gravity flow conveyor applications, extendable conveyors, flow rails, wheel rails and lift gates. Used primarily in Shipping, Warehousing and Assembly.
- Performance:** FRANTZ conveyor wheels undergo rigorous testing to assure years of satisfactory use. The FRANTZ Sterling® Steel Ball Division manufactures balls for the auto and defense industries under a Quality Management System registered to IATF 16949:2016.

...Roll Easy with FRANTZ®

FRANTZ

Customer Service, Product Samples and Quotations: 815.625.7063

FRANTZ Manufacturing Company P.O. Box 497, Sterling IL 61081-0497 www.frantz-mfg.com