

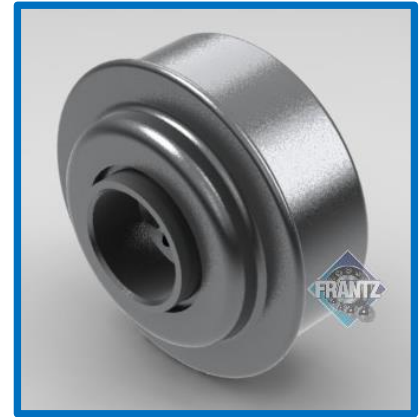

# 2510

## Unground / Commercial Bearing



### Specifications

- Bearing Type:** Flanged Unground Non-Precision
- Load Capacity:** 425 lbs.
- Mounting Type:** Press Fit
- Tube Size/Gauge:** 2.5" x 11g \*
- Max OD of Body:** 2.270"
- Bore Size & Type:** 11/16" – Hex
- Extension:** 0.486"
- Lubrication:** Oil or Grease
- Option:** All Stainless Steel Version
- Temperature Range:** Oil, -10 to 400 F°  
Grease, -4 to 284 F°
- Protection:** Front – Sealing Ring, Shield Plate  
Rear – Shield Plate
- Regreasable:** Yes – Inner Race Ports

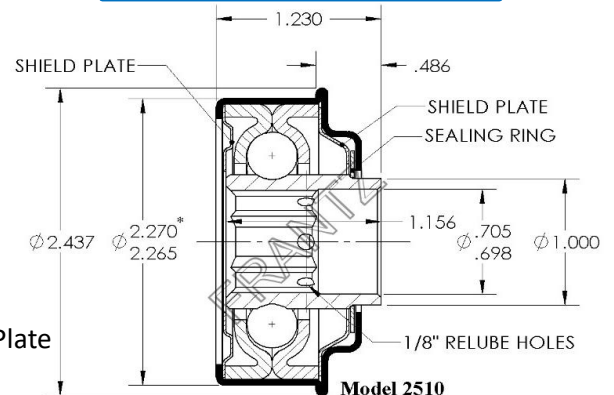

\*NOTE: Models in Stainless Steel have body diameter of 2.277/2.272

#### Part Number for Ordering:

Oil - 2510226023  
Grs - 2510226123

\* Also press fit into 2-1/2" x 12g, 2-5/8" x 7g and 2-3/4" x 1/4" tubes.

### Applications: Benefits & Features

- Non-Precision Bearing:** FRANTZ Unground / Commercial bearings offer the least rolling resistance, lower energy consumption and overall a greener option. Engineered to accommodate more axle deflection due to heavy loads or shock, especially when used in longer rollers (as compared to Precision or Semi-Precision bearings), often making commercial bearings the product of choice in many conveyor designs. Dual outer race and full ball complement provides more contact between components allowing for more resistance to shock loading.
- Targeted Applications:** Gravity or powered conveyor applications at low to medium speeds used primarily in packaging, palletizing, shipping/warehousing, cargo dollies and assembly.
- Ball Quality:** FRANTZ also manufactures the balls used in the 2510 under strict IATF 16949:2016 quality standards designed for supporting the requirements of the auto industry, thus providing another level of quality over competitive models.
- Long Life:** FRANTZ Unground / Commercial bearings are engineered and tested to exceed the CEMA standard or one million revolutions.

Customer Service, Product Samples and Quotations: 815.625.7063

FRANTZ Manufacturing Company P.O. Box 497, Sterling IL 61081-0497 [www.frantz-mfg.com](http://www.frantz-mfg.com)

...Roll Easy with FRANTZ®

FRANTZ