

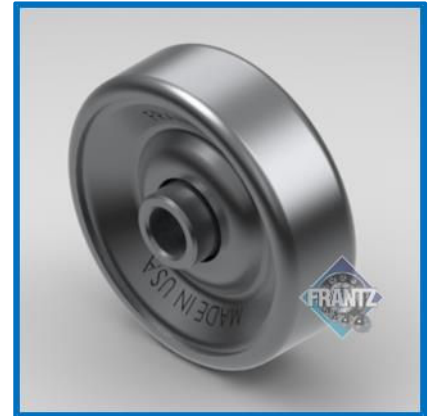

# 25

## Conveyor / Skate Wheel



### Specifications

- Wheel Type:** Non-Precision
- Load Capacity:** 100 lbs.
- Impact Rating:** 200 lbs.
- Body Diameter:** 1-15/16"
- Bore Size & Type:** 5/16" – Round; Length 13/16"
- Lubrication:** Oil or Grease
- Ball Complement:** (8) - 1/4" Diameter
- Material:** Zinc Plated Steel, Hardened Sterling® Steel Balls & Raceways
- Temperature Range:** Oil, -10 to 400 F°  
Grease, -40 to 120 F° \*\*
- Regreasable:** No – Maintenance Free
- Other:** Polyurethane tires, no lube, & extreme cold oil available; contact Customer Service

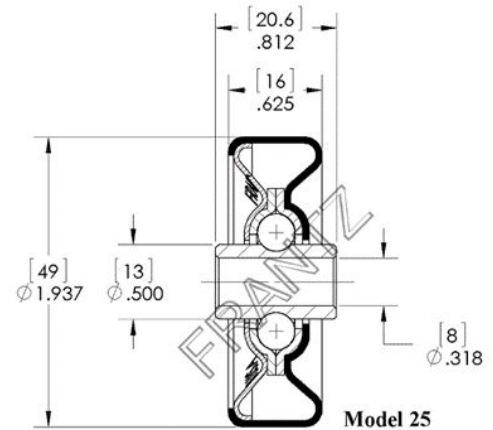

Part Number for Ordering:  
Oil - 0025216023  
Grs - 0025216123

\*\* If grease is required with application temperatures above 120 F° please consult with FRANTZ customer service to discuss application and options.

### Applications: Benefits & Features

- Impact Rating:** FRANTZ not only tests steel conveyor wheels for cycle revolutions under load, but also performs impact testing under ANSI spec ICWM:2012 which was developed for the caster industry. Impact rating provides user confidence in applications with heavy weight or load "impact zones".
- Targeted Applications:** Conveyor / skate wheels for straight or curved gravity flow conveyor applications, extendable conveyors, flow rails, wheel rails and lift gates. Used primarily in Shipping, Warehousing and Assembly.
- Performance:** FRANTZ conveyor wheels undergo rigorous testing to assure years of satisfactory use. The FRANTZ Sterling® Steel Ball Division manufactures balls for the auto and defense industries under a Quality Management System registered to IATF 16949:2016.

...Roll Easy with FRANTZ®

# FRANTZ

Customer Service, Product Samples and Quotations: 815.625.7063

FRANTZ Manufacturing Company P.O. Box 497, Sterling IL 61081-0497 [www.frantz-mfg.com](http://www.frantz-mfg.com)