

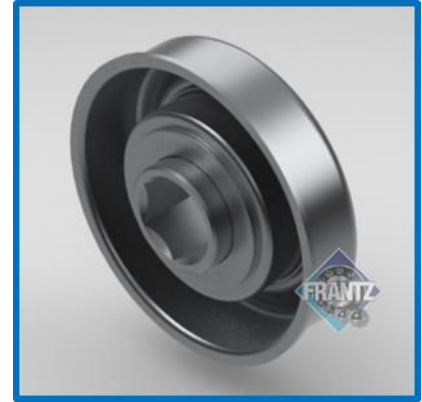

**FRANTZ**

# 1708

## Non-Precision Bearing



### Specifications

- Bearing Type:** Flanged Unground Commercial
- Load Capacity:** 140 lbs.
- Mounting Type:** Press & Swage Fit
- Tube Size/Gauge:** 1-7/8" x 13g
- Max OD of Body:** 1.704"
- Bore Size & Type:** 7/16" – Hex
- Extension:** 0.170"
- Lubrication:** Oil or Grease
- Temperature Range:** Oil, -4 to 400 F°  
Grease, -22 to 350 F°
- Regreasable:** No – Maintenance Free

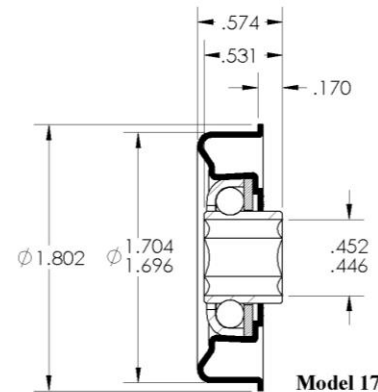

Model 1708

Part Number for Ordering: Oil – 1708000023  
Grs – 1708000123

### Applications: Benefits & Features

**Non-Precision Bearings:** FRANTZ Non-Precision bearings offer the least rolling resistance, lower energy consumption and overall a greener option. Engineered to accommodate more axle deflection due to heavy loads or shock, especially when used in longer rollers (as compared to Precision or Semi-Precision bearings), often making non-precision bearings the product of choice in many conveyor designs.

**Targeted Applications:** This bearing often used where a slightly smaller diameter tube is feasible, compared to traditional 1.9" x 16g roller use. Gravity conveyors for distribution/warehousing, food & beverage, air cargo/airports, manufacturing equipment and packaging equipment. The bearings are ideal in gravity applications at low to medium speeds, while the oil version offers the least rolling resistance.

**Long Life:** FRANTZ non-precision bearings are engineered and tested to exceed the CEMA standard of one million revolutions.

**FRANTZ**

...Roll Easy with FRANTZ®

Customer Service, Product Samples and Quotations: 815.625.7063

FRANTZ Manufacturing Company P.O. Box 497, Sterling IL 61081-0497 [www.frantz-mfg.com](http://www.frantz-mfg.com)