



1276

Non-Precision Bearing



Specifications

- Bearing Type:** Flanged Unground Commercial
- Load Capacity:** 47 lbs.
- Mounting Type:** Press & Swage Fit
- Tube Size/Gauge:** 1-3/8" x 18g
- Max OD of Body:** 1.277"
- Bore Size & Type:** 5/16" – Hex
- Extension:** 7/32"
- Lubrication:** Oil or Grease
- Temperature Range:** Oil, 0 to 400 F°
Grease, -40 to 300 F°
- Inner Race:** Machined & burnished ball groove, case hardened
- Outer Race:** Press formed and case hardened
- Balls:** Precision ground carbon steel, case hardened
- Regreasable:** No

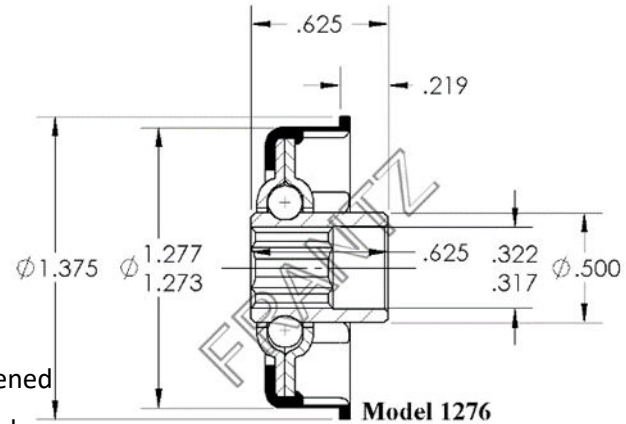

Part Number for Ordering:
Oil - 1276000023
Grs - 1276226123

Applications: Benefits & Features

Non-Precision Bearings: FRANTZ Non-Precision bearings offer the least rolling resistance, lower energy consumption and overall a greener option. Engineered to accommodate more axle deflection due to heavy loads or shock, especially when used in longer rollers (as compared to Precision or Semi-Precision bearings), often making non-precision bearings the product of choice in many conveyor designs.

Targeted Applications: Gravity or powered conveyor applications at low to medium speeds requiring a small tube diameter used primarily in packaging, shipping, warehousing and assembly.

Long Life: FRANTZ non-precision bearings are engineered and tested to exceed the CEMA standard of one million revolutions.

FRANTZ

...Roll Easy with FRANTZ®

Customer Service, Product Samples and Quotations: 815.625.7063

FRANTZ Manufacturing Company P.O. Box 497, Sterling IL 61081-0497 www.frantz-mfg.com