



1100

EZ™ Glider Ball Transfer



Specifications

- Ball Transfer Type:** Flange Mount
- Load Capacity:** 150 lbs. - Carbon Steel Ball
- Mounting Type:** Flange Mount with (2) 0.219" mounting holes
- Height:** 1.189"
- Max OD of Body:** 1.156" (Shoulder)
- Housing Material:** Zinc Plated Carbon Steel
- Main Ball Size and Material:** 1"; Carbon Steel
- Main Ball Options *:**
 - Polypropylene
 - Metric, Carbon Steel
 - Stainless Steel 'SS' - All Stainless Steel incl. 'Minor' Balls
- Minor Ball Material:** Carbon Steel
- Temperature Range:**
 - Carbon Steel -4°F to 400°F
 - All Stainless -4°F to 850°F
 - Polypropylene 15°F to 190°F

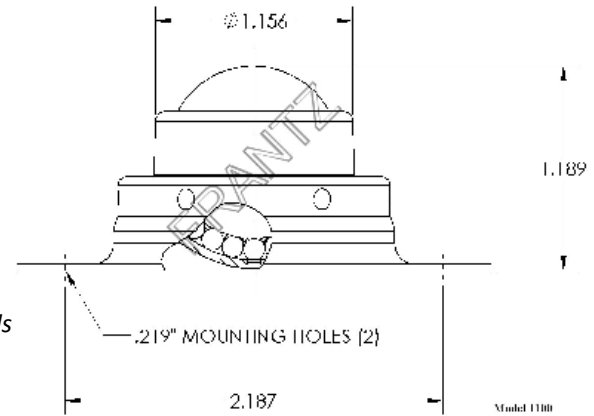

Part Number for Ordering: (Main Ball – 3/4" Bolt)
 Carbon Steel - 1100226023
 ALL Stainless - 1100726023
 Polypropylene - 1100236023

Applications: Benefits & Features

- Targeted Applications:** Omni-directional material handling. Great for manufacturing, packaging, assembly, loading of semi-trailers or air cargo, warehousing and specialized wood-working accessories. Virtually limitless applications in the movement of thousands of objects.
- Ball 'UP' or 'Down' and Unique 'Shoulder' Design:** The 1100 series can also be used in a ball 'down' position in place of a caster. Patented shoulder/neck design – for details on application benefits, visit www.frantz-mfg.com/general_information.aspx?id=153
- Quality and Long Life:** FRANTZ manufactures balls for the auto industry under strict IATF 16949:2016 quality standards. FRANTZ operates a state-of-the-art test lab to measure products against ABMA standards including roundness, surface roughness, case depth and hardness. This assures an additional level of quality.

*Polypropylene provides non-marring options for sensitive surfaces. Each provide various load ratings and benefits based on chemical and application environments. Contact FRANTZ Customer Service if you have questions regarding specific applications to assure correct product use.

...Roll Easy with FRANTZ®

FRANTZ

Customer Service, Product Samples and Quotations: 815.625.7063

FRANTZ Manufacturing Company P.O. Box 497, Sterling IL 61081-0497 www.frantz-mfg.com