

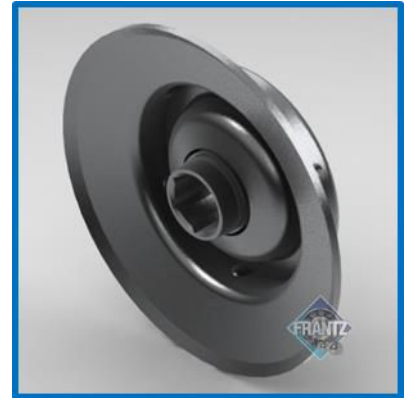

# 1015

## Non-Precision Bearing



### Specifications

- Bearing Type:** Wide Flanged Unground Commercial
- Load Capacity:** 140 lbs.
- Mounting Type:** Press Fit \*
- Tube Size/Gauge:** 1.9" x 16g
- Max OD of Body:** 1.782"
- Bore Size & Type:** 7/16" – Hex
- Extension:** 0.281"
- Lubrication:** Oil or Grease
- Temperature Range:** Oil, -10 to 400 F°  
Grease, -40 to 300 F°
- Front Protection:** Optional Polymer Seal
- Regreasable:** No

\* Also, heavy press fit into 2" x 11g tube.

**Press Fit or Locking Fit** – Designed with 'dimpled' stakes to lock in to roller tubes securing the inner race to the outer race. This requires a crimp tool but the end result enables the bearing to hold up to higher lateral forces.

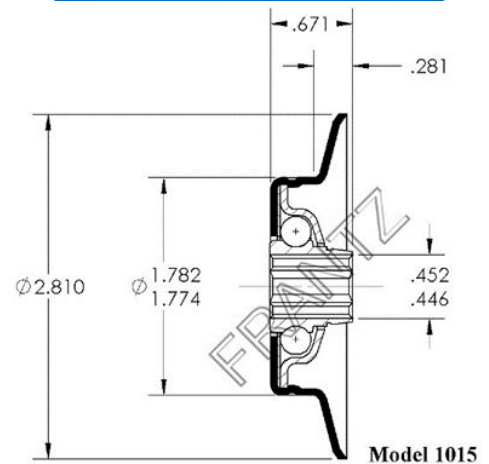

Model 1015

Part Number for Ordering:

- Oil - 1015226023
- Grs - 1015226123

### Applications: Benefits & Features

**Non-Precision Bearings:** FRANTZ Non-Precision bearings offer the least rolling resistance, lower energy consumption and overall a greener option. Engineered to accommodate more axle deflection due to heavy loads or shock, especially when used in longer rollers as compared to Precision or Semi-Precision bearings.

**Targeted Applications:** Wide flange "Guide Wing" bearings for guiding cartons and containers on straight conveyor sections and flow racks. Integrated side guide eliminates separate flange either welded or pressed on to the roller tubes. Additionally, depending on carton dimensions, may provide an alternative to tapered rollers on curved conveyors as the wide flange provides an economical option. Gravity or powered conveyor applications at low to medium speeds used primarily in packaging, shipping, warehousing and assembly.

**Long Life:** FRANTZ non-precision bearings are engineered and tested to exceed the CEMA standard of one million revolutions.

Customer Service, Product Samples and Quotations: 815.625.7063

FRANTZ Manufacturing Company P.O. Box 497, Sterling IL 61081-0497 [www.frantz-mfg.com](http://www.frantz-mfg.com)

FRANTZ

...Roll Easy with FRANTZ®