



0005 / 0006

Conveyor / Skate Wheels

Specifications

- Wheel Type:** Non-Precision
- Load Capacity:** 100 lbs.
- Body Diameter:** 1-15/16"
- Color:** 0005 – Black
0006 - White
- Bore Size & Type:** 1/4" – Round
- Surface Area:** 0.625"
- Lubrication:** Dry (Includes Bushing)
- Material:** Acetal Hub &
Zinc Plated Steel Bushing
- Temperature Range:** -40° to 250° Fahrenheit
- Regreasable:** No – Maintenance Free

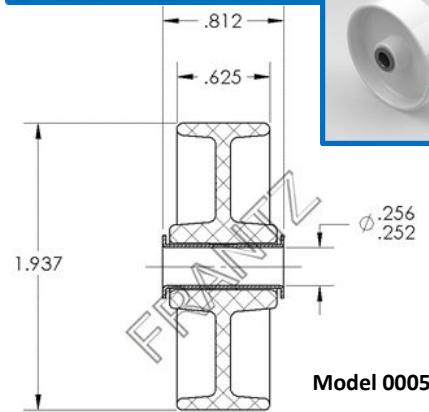
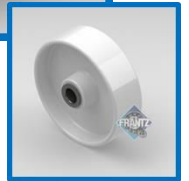

Model 0005 & 0006

Part Number for Ordering:
0005 - 0005000023 0006 - 0006000023

Applications: Benefits & Features

Quality / Impact Resistance: FRANTZ has modified the traditional design of these types of plastic wheels after repetitive modeling and testing. We believe an optimal design has been achieved to improve the impact resistance as well as to provide 100 lbs. of dynamic load rating.

Targeted Applications: An economical wheel choice in many conveyance applications due to the wheels' relatively high strength and low cost. The light weight also presents the plastic wheels as the product of choice (along with aluminum wheels) where low weight is required in application.

Great for many gravity, carton rack, portable and expandable conveying applications and systems. Plastic wheels also should be considered where a non-marring application is needed.

Long Life: The 0005 / 0006 wheels have been put through CEMA's bearing life load testing and have exceeded the test's criteria of 1 million revolutions (at 100 lbs.) by a factor of over 2 times. The test was recorded at 135 RPM / 68 SFM.

...Roll Easy with FRANTZ®

FRANTZ

Customer Service, Product Samples and Quotations: 815.625.7063

FRANTZ Manufacturing Company P.O. Box 497, Sterling IL 61081-0497 www.frantz-mfg.com